

Super ~ Giant-L Hoop-It-All™

The answer to your EXTRA Long embroidery inspirations

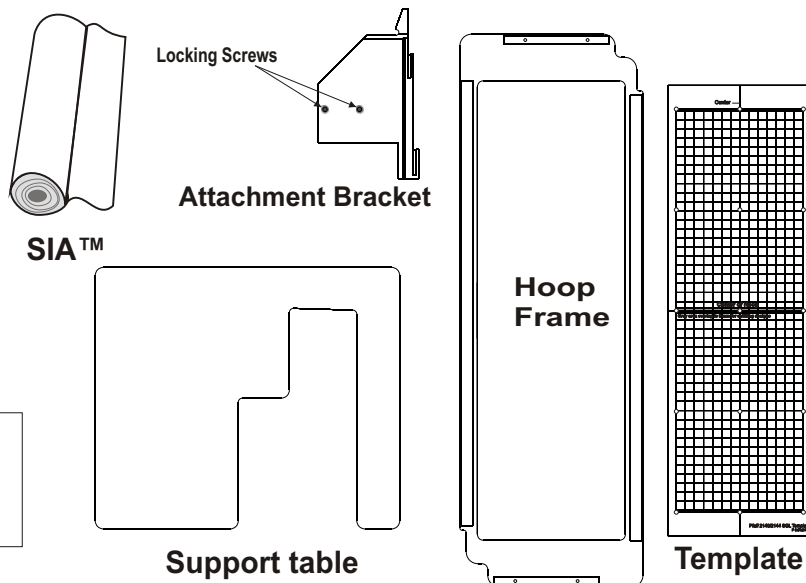

*** When Ordered as part of a Combo Kit, only 1 Support Table and 1 Attachment Bracket is included for all hoops!**

Patent # 5,555,828
Patent # 2,179,119
Other patents pending

Fits Pfaff 2134, 2140, 2144, 2170

For assistance with this hoop and for more information or future purchases of Hoop-It-All™ stabilizers, visit your local Hoop-It-All retailer or call for a dealer near you at (800) 947-4911 or email info@hoopitall.com.

GIANT-L Hoop-It-All Kit Includes:

- Hoop-It-All™ Frame
- S-I-A™ Pressure-Sensitive Adhesive Tearaway Sample Sheets
- Illustrated Instructions
- * Attachment Bracket
- * Support Table

Embroidery Solutions™
HOOP-IT-ALL INC.
www.hoopitall.com
Difficult Embroidery Projects Made Simple

Buy the Multi-Purpose BIG Cap Hoop-It-All™ accessory kit and use attachment bracket enclosed in this kit.

About the Super Giant Long Hoop-It-All

The Super-GIANT-L Hoop-it-All makes it possible to embroider two 140mm x 225mm designs with a 6mm overlap in the center in one hooping from top to bottom without the need of removing the fabric off the hoop frame for a total of 140mm W x 544mm L.

The paper template helps in placement of designs by indicating the overlap of the sewing fields.

SIA™ Adhesive Tearaway Stabilizer

Your new Hoop-It-All™ kit includes, SIA™ adhesive stabilizer. This stabilizer is necessary for proper hoop function. The fabric is held on the hoop by first attaching the SIA™ to the back of the hoop frame with the adhesive side facing up.

Using this method of hooping makes it possible to embroider any fabric without stretching the material, eliminating puckers, distortion or damage to the delicate fibers. No unsightly hoop marks will be left on velvet, suede or corduroy. Also you can embroider anywhere on garments without interference from seams, pockets, facings, zippers, buttons, etc. You can embroider on any item that the needle will penetrate, and that fits under the embroidery foot of your machine. Even small items such as collars, cuffs, straps, socks, ties, and gloves easily adhere to the stabilizer, making it possible to embroider on them.

Placing & removing Hoop-It-All™ from embroidery arm.

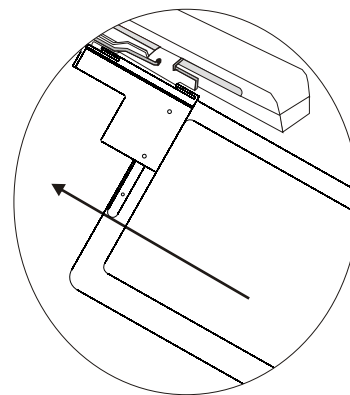

To attach Hoop-It-All to embroidery arm, align the mounting bracket with the embroidery arm's bracket holder and slide on the same as you would do to the frame that came with your machine. Make sure the lever locks down and keeps the mounting bracket in place.

To remove the Hoop-It-All, lift the lever and slide the bracket out.

Make sure the mounting bracket slides on the rail all the way until it stops.

Extension Support Table

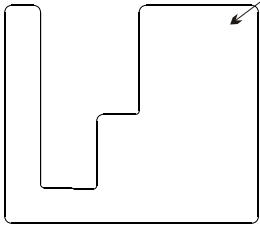

- 1) Before starting to embroider, position the HIA support table around the machine, with the fatter side in the front of the machine and the skinny in the back of your machine.

PLEASE NOTE: The Support Table is not included in the Accessory kit. The table is included in the Combo-Plus, Combo, Complete Double-Wide, or Complete Giant-L kits. If you did not understand this at the time of purchase it can be ordered separately at an additional cost.

Stabilizing Fabric for Embroidery

Cut a piece of Hoop-It-All's **FaBond™** tear-away stabilizer larger than the embroidery design and with a hot iron press it to the back of the fabric. **FaBond™** helps to stabilize fabric and easily removes after embroidery is done. This stabilizer also makes it easier to peel off remaining **SIA™** from back of fabric. **FaBond's™** unique coating cools your sewing machine needle, aiding in keeping it clean and free from any possible adhesive build-up. For extra stability lay one layer of Hoop-It-All's **dSV™** water soluble film on top of the fabric.

Preparing the Fabric

After stabilizing place the frame on top of the fabric (Fig 9) where the embroidery will be sewn. Using a chalk marker or water soluble pen mark center lines on the fabric across the entire opening of the frame and trace around the inner frame edge to help with placement on the hoop. Match the center lines on the paper Placement Template (Fig 2 front page), with those marked on the hoop frame. At the same time become familiar with the Placement Template.

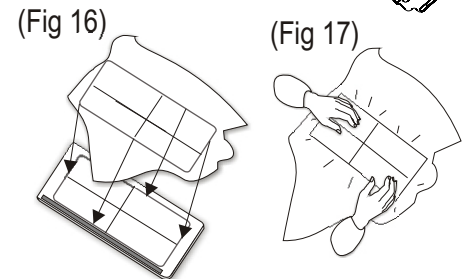
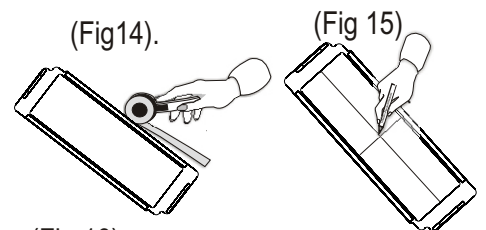
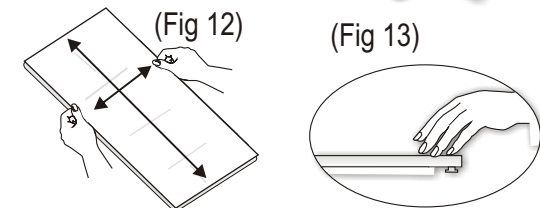
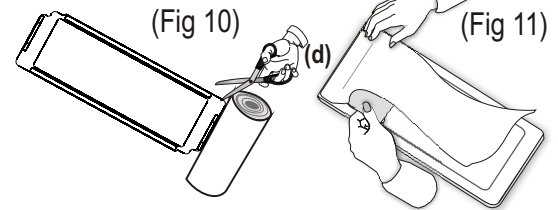
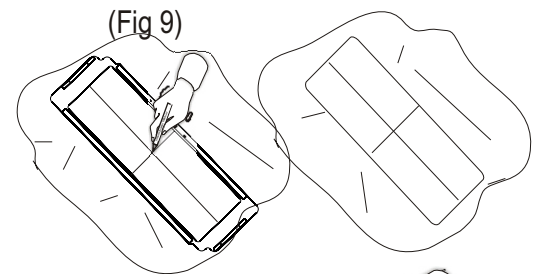

Preparing the Hoop-It-All™ for Embroidery

- 1) Place hoop frame face-down on a flat surface.
- 2) Cut a piece of **SIA™** 23" long (Fig 10), from the roll provided in your kit
- 3) Slowly peel back 2" to 3" of release liner (paper backing on **SIA™**) and attach adhesive side down to backside of hoop frame on one end.(Fig 11)
- 4) Start pulling release liner off while pressing **SIA™** stabilizer to the sides and lower rim of hoop frame (Fig 12) making sure it is taut.

Be careful not to stretch the SIA™ too tight or the frame will bow.

- 5) Hand press the **SIA™** adhesive tear-away stabilizer firmly along entire surface of hoop frame, to ensure it adheres properly. (Fig 13)
- 6) Place hoop on a cutting mat and carefully cut away any excess **SIA™** (Fig14) stabilizer extending out from edges of hoop frame with a rotary cutter . It is important that the **SIA™** does not interfere with the movement of the Sliding Bracket as the machine senses the hoop. Any excess **SIA™** around the hoop frame could cause the machine not to recognize the hoop.
- 7) Place hoop face up on a flat surface and draw center lines directly on the **SIA™** (Fig 15) to help with placement. Use the marks on hoop frame as a guide.
- 8) Lay fabric over **SIA™** matching the lines you traced of the inside edge of hoop frame, with the frame's inner edge. (Fig 16) Match cross lines drawn on **SIA™** with those drawn on fabric. A light box under the hoop is also helpful with placement.

Attaching Bracket to Hoop Frame

1) Loosen, but do not remove, the 2 Locking Screws on bracket. (a)

2) Line up the slot located under bracket with the gold rail on hoop frame and slide it on.

3) Slide frame until in all the way until it stops. Finger tighten the 2 Locking Screws so that they are resting on the top of the gold rail and hoop does not move. Do not over tighten. Use the machine's edit Feature to move the needle right or left to the center

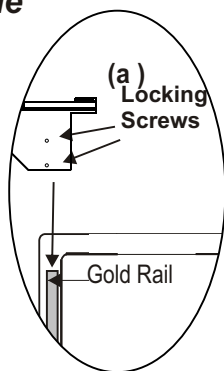

Planning your design

- 1 - Refer to page 1 of these instructions regarding the embroidery field possibilities.
2. Compare the hoop's paper template with the machine's template.
3. Mark center lines for each design (Fig 19).

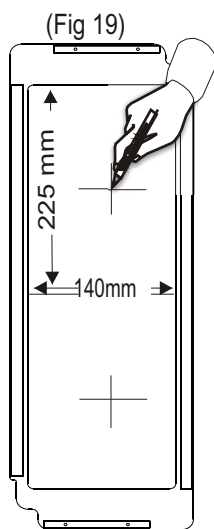

4. Attach bracket to hoop frame. Embroider first design (fig. 20).



(fig. 20)

5. Remove bracket and place on other end of hoop. Embroider next design (fig. 21). REMEMBER to rotate your design 180 degrees so that both designs will match up.



(fig. 21)

Embroidering multiple Designs

When possible use a Design Template to help with placing the designs on the fabric.



- 1) Mark placement lines for each design on fabric (Fig 20).
- 2) Match cross lines on Design Template with those marked on fabric.

dSV™ Water Soluble Film-

We also recommend placing one layer of **dSV™ water soluble film** by Hoop-It-All™ on top of the fabric. This film aids with further stabilizing the fabric, keeps high nap fabrics from interfering, and gives a nice dimension to the embroidery thread.

S-dSV™ "Adhesive-backed" Water Soluble Film -

(An exclusive product by Hoop-It-All, Inc.)

This stabilizer is used in place of **SIA™** when embroidering on sheer fabrics, to make lace or whenever the back of the fabric may be seen such as on towels and lapels. To create lace motifs, place on back of the Hoop frame with the adhesive side facing up and then add one layer of the "non-adhesive" backed dSV™ on top to make beautiful lace. When rinsed in tap water only the lace remains.

dry Cover-Up™ Vinyl Topping

This topping is available in 16 colors including clear. It comes in two separate packages of 8 assorted colors each including clear. When ordering choose between primary or optional colors. Place a piece of dryCover-Up™ on top of the fabric where fill stitches appear. The color choice should be closely related to the color of thread to help prevent the fabric showing through the embroidery. This is a permanent topping which lifts the embroidery and keeps your embroidery looking "like new" wash after wash. It is also available in rolls of one selected color.

Turn the page and let's get started using your new Hoop-It-All™